

S. BROWN.  
 Lathe Attachment for Turning Lathe-Centers.  
 No. 221,392.                      Patented Nov. 11, 1879.

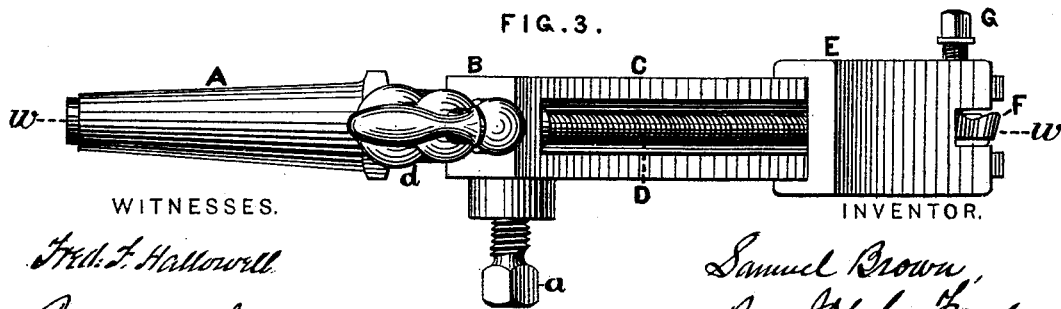
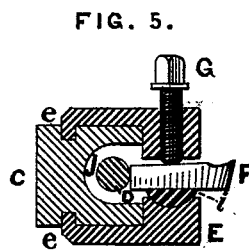
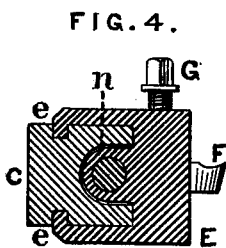
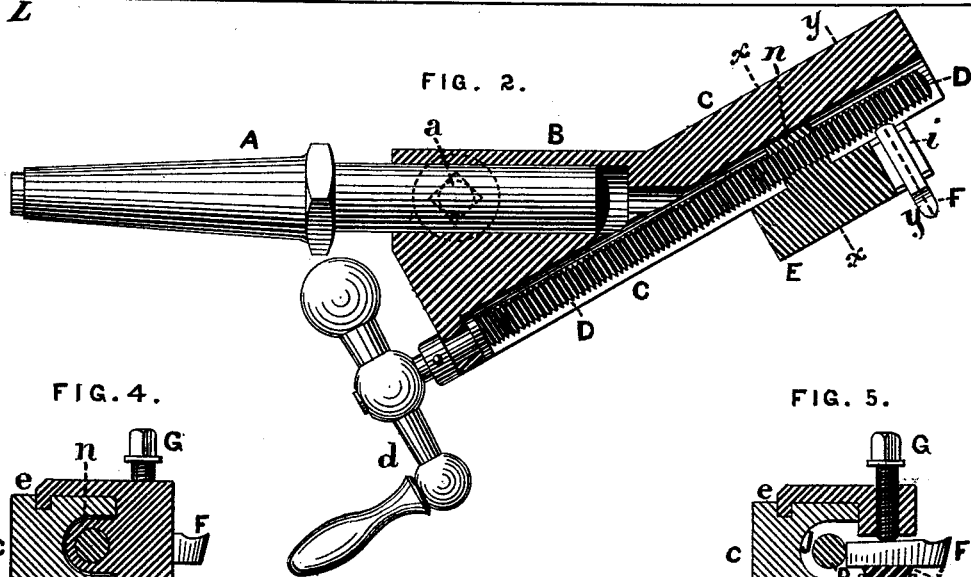
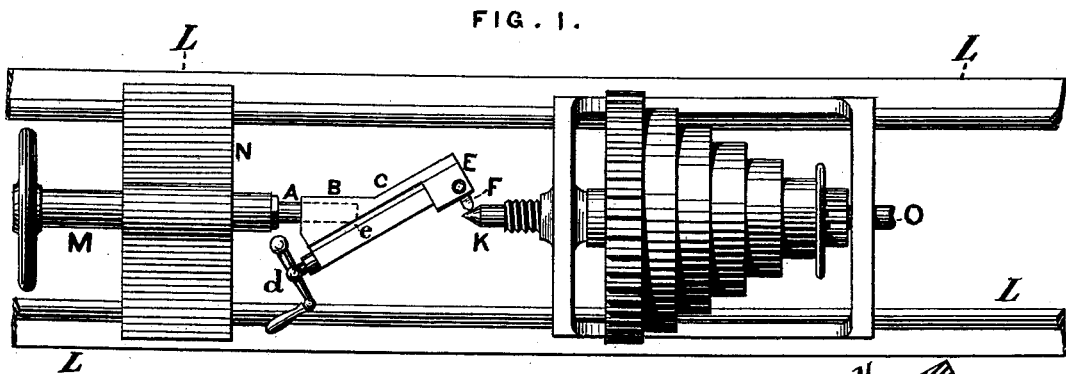

WITNESSES.  
*Wm. L. Hallowell*  
*Richard S. Hunter*

INVENTOR.  
*Samuel Brown,*  
 By *W. C. Fraley*  
 Attorney.

# UNITED STATES PATENT OFFICE.

SAMUEL BROWN, OF PHILADELPHIA, PENNSYLVANIA.

## IMPROVEMENT IN LATHE ATTACHMENTS FOR TURNING LATHE-CENTERS.

Specification forming part of Letters Patent No. 221,392, dated November 11, 1879; application filed August 13, 1879.

*To all whom it may concern:*

Be it known that I, SAMUEL BROWN, of Philadelphia, in the State of Pennsylvania, have invented a new and useful Lathe Attachment for Turning Lathe-Centers, whereof the following is a specification, reference being had to the accompanying drawings.

Of these, Figure 1 is a plan view, showing my attachment in position in a lathe. Fig. 2 is a longitudinal section through the line *ww* of Fig. 3. Fig. 3 is a view, in perspective, at right angles to the position shown in Fig. 2; and Figs. 4 and 5 are cross-sections on the lines *xx* and *yy*, respectively.

Heretofore it has been customary in turning lathe-centers either to guide the cutter by hand or by means of a compound rest attached to the ways or bed of the lathe. The former of these methods requires much care and skill on the part of the workman, and the latter necessitates the use of a complicated and expensive apparatus, and one, moreover, for which some lathes are not adapted.

My invention consists in so arranging the cutter and its guiding and actuating devices that the whole can be attached directly to the tail-stock of an ordinary lathe. Thus I obtain great accuracy and uniformity of operation with a simple and compact device.

A stout mandrel, A, adapted to fit upon the dead-center or tail-stock M N of the lathe, fits into a socket in the butt B of my attachment, where it is firmly secured by a set-screw, *a*. From this butt the straight guide-piece C projects, inclined at an angle of thirty degrees to the axis of the mandrel, and consequently at the same angle to the axis M O of the lathe. The guide-piece C is provided with longitudinal grooves *ee* upon its sides, and a deeper one, J, upon its face. A screw, D, turned by winch *d*, is arranged within the groove J, and passes through the nut *n* of the tool-carrier E. This carrier E overlaps the sides of the guide-piece C, and fits into the grooves or ways *ee*, and the cutter F is fixed in the carrier E by means of the set-screw G and adjustable seat *i*.

The operation is as follows: The attachment being fixed in the lathe L L, as shown in Fig. 1, the carrier E is run backward toward the

winch *d* until the point of the cutter F passes the axis of the lathe. The piece K, from which the center is to be made, is then adjusted upon the live-center or head-stock, and as the lathe is run the winch *d* is slowly revolved, moving the cutter F diagonally across the axis, and thus turning the center K with a uniform angle.

It is also obvious that the angle of adjustment of the guide-piece C may be varied without changing the nature of the device; but for the purposes of illustration the ordinary one of thirty degrees has been selected.

It is also obvious that the method of guiding and actuating the cutter may be changed without affecting my invention, provided that when the device is affixed to the tail-stock the guide has a definite inclination to the lathe-axis.

In order to adapt the attachment to lathes of various sizes, I provide it with several mandrels, whose tapering ends are of different diameters, and thus one instrument will suffice for the work of a large establishment, and in some cases it may be found convenient to insert the puppet-head of the tail-stock directly into the socket of the butt B.

I claim—

1. In a lathe attachment for turning lathe-centers, the combination of an inclined guide-piece, cutter, and its actuating device with a mandrel, whereby the whole may be carried upon the tail-stock, substantially as described and shown.

2. In an attachment for turning lathe-centers, the combination, with a cutter and its actuating device, of a guide-piece, provided with a socket to receive the puppet-head of the tail-stock, and having a definite inclination to the axis of such socket, substantially as described and shown.

3. The combination of the tail-stock of a lathe with a cutter and its actuating device, and an inclined guide-piece, substantially as described and shown.

SAMUEL BROWN.

Witnesses:

WM. H. MYERS,  
RICHARD S. HUNTER.